



## Elegant 200

### VBLTL-200-4-GU10



Track lighting supplies a highly dynamic lighting option with individually adjustable spotlights along an adjustable railing system. A single track lighting system could simultaneously light several different objects located around the room making this system ideal for displays either retail or personal. Equipped with a GU10 Compatible lamp holder, a high strength shockproof steel body, instant start, 50,000 hour lifespan and a 3 year warranty.

### Features & Benefits

- Wattage: 35W
- Body Colour: White
- GU10 Lamp holder. Use in conjunction with VBEL-GU10-TB-3K/5K
- Equipped with CITIZEN LED chips
- High strength Steel Housing
- 40° beam angle
- Also available in white body colour
- Built in driver
- Instant on, no flickering
- 50,000 hours lifespan
- 3 year warranty



## Specifications

<b>SKU</b>	VBLTL-200-4-GU10
<b>Track type</b>	Single Circuit
<b>EAN</b>	9340994407401
<b>Light Colour</b>	CCT
<b>IP rating</b>	20
<b>CRI</b>	95
<b>Beam Angle</b>	40 Degrees
<b>Trim colour</b>	Black
<b>Diameter</b>	65 mm
<b>Height</b>	138 mm
<b>Warranty</b>	5 Years
<b>Dimmable</b>	Dimmable
<b>Mounting type</b>	Track
<b>Material</b>	High strength Steel housing
<b>Dimming</b>	Triac Dimming
<b>Input voltage</b>	220V-240V AC 50HZ
<b>Weatherproof</b>	Non-weatherproof
<b>Working temperature</b>	-20°C ~ 50°C



## Dimensional Drawings

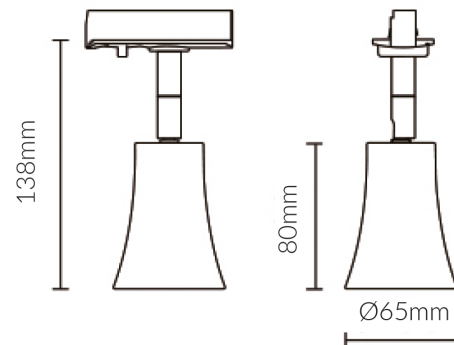

*Photometric information available upon request.*