

Driveway Lite

Cat. No. DWL

Cat. No. DWLGU



The Driveway Lite is a luminaire designed to mount flush with the level of the driveway, pathway, hotel floors or building foyer. It has a 'Flush Fit' lens which stops water pooling and depositing dirt on the lens. There is no lip to trip over.

The Driveway Lite is supplied with a mounting canister that facilitates ease of installation. The luminaire can be driven over or walked upon without being damaged. Designed so the lamp can be angled up to 20 degrees, directed at a bush, tree, or the outside of a building, etc. without the need to remove the luminaire from the mounting canister due to the vandal-resistant three allen head screw fixing system which attaches the flange to the body of the luminaire. This luminaire has a solid bronze or 316 stainless steel flange with a powder coated black body.

A GU10 version of this luminaire is also available for line voltage lamps.

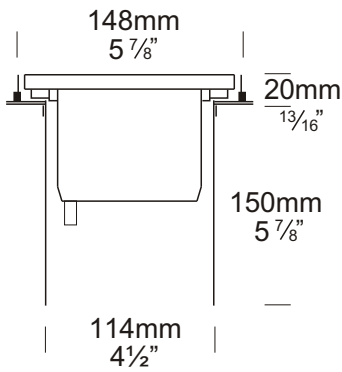

Ordering Information

Luminaire Type	Flange Option	Body	Accessories
DWL - Driveway Lite	SBZ - Solid Bronze SS - 316 Stainless Steel	Black only	CJK150 - Cable Joint Kit HCR - Hex Cell Retainer STEPLLF - Frosted Lens GU - GU10 Option
			For LED options, refer to page 10.4.3 (6 watt) or 10.4.4 (3 watt) or http://hunza.co.nz/l.html

Ordering Example: DWL SBZ - Driveway Lite with Solid Bronze flange.
DWLGU SBZ - Driveway Lite GU10 with Solid Bronze flange.
STEPLLF - Frosted Lens
(Accessories ordered separately)



HUNZA™ PURE OUTDOOR LIGHTING

HUNZA FACTORY
130 Felton Mathew Ave
Glen Innes
Auckland 1072
New Zealand

Ph: 64-9-528 9471
Fax: 64-9-528 9361
hunza@hunza.co.nz
www.hunza.co.nz

INTERNATIONAL CONTACTS:
www.hunza.co.nz/contacts.php

Specifications may change without notice.
Manufactured in New Zealand.
© 2011 Hunza Holdings Ltd.

Ver 1.4

Luminaire Construction

Body:

Cast from virgin high corrosion resistant CC401 low copper aluminium alloy, with chromate substrate and high UV resistant black polyester powder coat.

Flanges:

The flange is attached to the body by three 316 stainless steel allen head anti vandal screws and is available in either

Solid bronze - 150mm (6") bar.

316 Stainless Steel - 150mm (6") rod.

Mounting

Supplied with a mounting canister for casting in concrete to facilitate ease of installation. The luminaire can be driven over or walked upon without being damaged. Maximum drive over speed 10 km/h (6 mph) and weight 1500kg (3300lbs).

Features

Lens:

12mm (½") flush fit clear tempered shatter resistant glass.

Lifetime Warranty.

Gasket:

Nytrol 220°C (428°F).

Lamp Holder:

GU5.3 & GU10 - 350°C (662°F) ceramic multi contact lamp holder with 250°C (480°F) teflon cables.

Accessories:

Cable Joint Kit (Cat. CJK150).
Not approved for USA/Canada.
Frosted Lens (Cat. STEPLLF).
Hex Cell Retainer (Cat. HCR).
GU10 Option (Cat. GU).

Standards

Ip67



UL1838

Luminaire Weight

BRZ 1.950kg (4lb 4oz)

SS 1.900kg (4lb 3oz)

Power Supply

HUNZA™ Inground or Wall Mount
Transformer: not included.

USA and Canada:

HUNZA™ Inground or Wall Mount
Transformer: not included.

Luminaire: supplied with

MR16 GU5.3 20 or 35 watt lamp max.

GU10 - GU10 25 or 35 watt lamp max.

LED - Refer to previous page.

USA and Canada:

MR16 GU5.3 20 watt lamp max.

GU10 Halogen - Lamp not supplied.

LED - Refer to previous page.

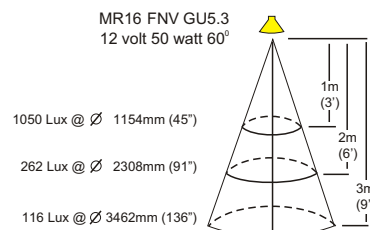
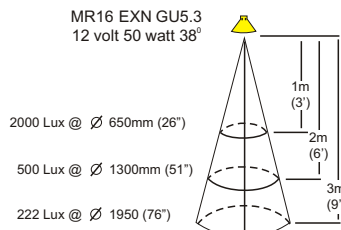
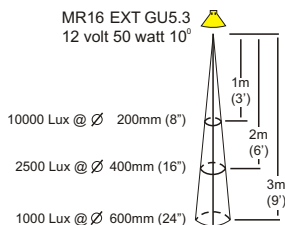
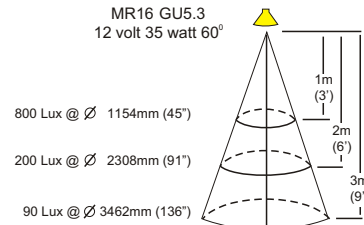
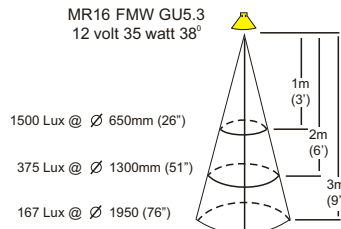
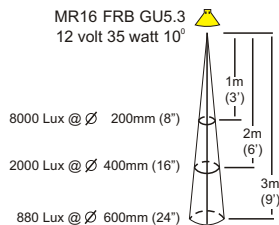
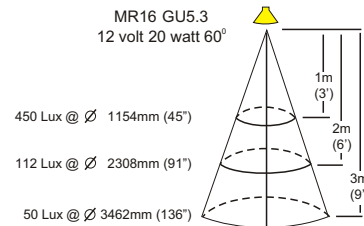
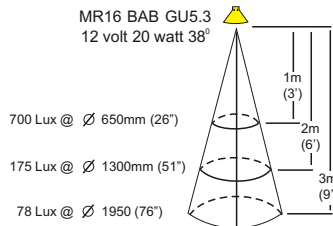
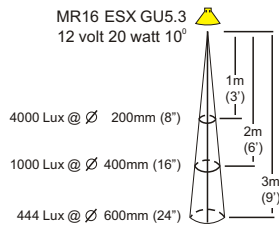

HUNZA™ PURE OUTDOOR LIGHTING

HUNZA FACTORY
130 Felton Mathew Ave
Glen Innes
Auckland 1072
New Zealand

Ph: 64-9-528 9471
Fax: 64-9-528 9361
hunza@hunza.co.nz
www.hunza.co.nz

INTERNATIONAL CONTACTS:
www.hunza.co.nz/contacts.php

Specifications may change without notice.
Manufactured in New Zealand.
© 2011 Hunza Holdings Ltd.

Ver 1.4