



# NOVADLUX02

LED Dimmable with **CHANGEABLE FACEPLATE(via clip)** Recessed Downlights

**TRI-CCT** 3000K 4000K 5700K

- Input voltage range: 220-240V 50/60Hz
- Inbuilt constant current driver included
- Housing: aluminium & plastic
- Faceplate: White: plastic
- Faceplate: Satin chrome, matt black & brass: aluminium
- Diffuser: frosted PC
- Tri-CCT (3000K/ 4000K/ 5700K) in one fitting
- CCT switch on side
- LED chip: 20pcs SMD2835
- Power factor: 0.9
- CRI: ≥80
- Flex & plug: 600mm
- Ambient temperature: -20 to 40°C
- Suitable for dimming
- Suitable for 2-way switching
- Suitable for use with sensors



Tri-CCT switch on side

**NOVADLUX02 Box Include:**

- 1x Downlight (NOVADLUX02) with white faceplate
- 1x Loose Satin Chrome (NOVADSC02) faceplate

30,000hr Lifetime	90° Beam Angle	IP44 Rated	DIMMABLE	3 YEAR Replacement Warranty
-------------------	----------------	------------	----------	-----------------------------

**Tested & Recommended Dimmers:**

BRAND	PART NO.	PCS PER DIMMER
CLA	LYNX	NOVADLUX02: 1-10PCS
CLIPSAL	32E450TM	
HPM	CAT400T	
DIGINET	MEDM, MMDM/RT	



NOVADLUX02



NOVADSC02

**Available faceplates (Sold Separately):**

- Matt Black (NOVADBLK02)
- Antique Brass (NOVADBR02)



NOVADBR02



NOVADBLK02

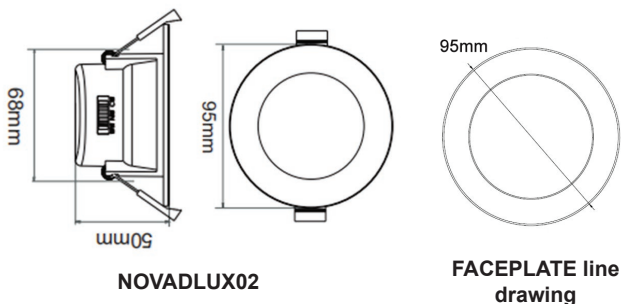

NOVADLUX02

FACEPLATE line drawing

PART NO.	DESCRIPTION	LUMENS			WATT	PRODUCT DIMENSIONS (mm)	CUT OUT (mm)	BOX WEIGHT (kg)	BOX DIMENSIONS (cm)	CARTON QTY
		3000K	4000K	5700K						
NOVADLUX02	D/L LED FIXED WH+S/C DIMM RND TRI	640lm	720lm	680lm	8	Ø95x50	Ø70	0.18	10.5x10.5x6.5	1/50
NOVADBLK02	FACEPLATE TO SUIT NOVADLUX02 MATT BLK OD 95mm									
NOVADBR02	FACEPLATE TO SUIT NOVADLUX02 ANTIQUE BRASS OD 95mm									